

## Smart lift SL580







Product information and specifications

# Smart lift SL580

## STANDARD EQUIPMENT

- 24 volt propelling engine with 1000 Watt
- Reliable 2 circuit vacuum system
- Side shift 100 mm to each side
- 24 volt reliable actuators for precise installation of item
- 4 large suction pads (Ø 400 mm) carry each 580 kg
- Functional accelerator
- Flexible 180 degrees turning head
- 2 circuit vacuum system
- Handy and compact
- Multifunctional
- Self-driven
- Improves work environment
- Staff saving
- Attractive price

## DIMENSIONS

	Width (min) .....	<b>780 mm</b>
	Length (min) .....	<b>1700 mm</b>
	Extention of arm .....	<b>500 mm</b>
	Side shift .....	<b>100 mm</b>
	Height .....	<b>1420 mm</b>
	Tip from horizontal .....	<b>35° backwards / 100° forward</b>
	Propelling engine .....	<b>1000 Watt</b>
	Battery (2 x 12 V) 24 Volt .....	<b>2 x 90 A</b>
	Running period .....	<b>Approx. 30 hours</b>
	Integrated charger .....	<b>Cetek XT 14000</b>
	Charging time .....	<b>Approx. 8 hours</b>
	Voltage charger .....	<b>230 volt</b>
	Vacuum system .....	<b>2 circuits</b>
	Suction pads .....	<b>4 x Ø400 mm</b>
	Automatic suction .....	<b>Yes</b>
	Weight .....	<b>697 kg</b>

## LOADING DIAGRAM

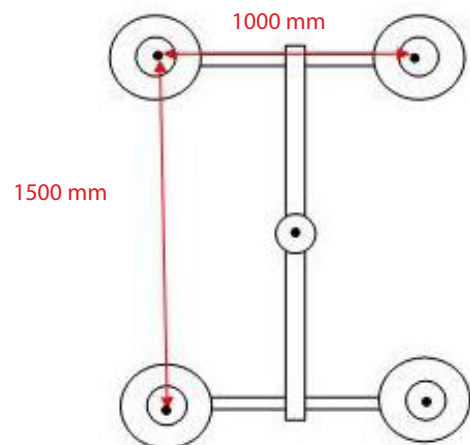
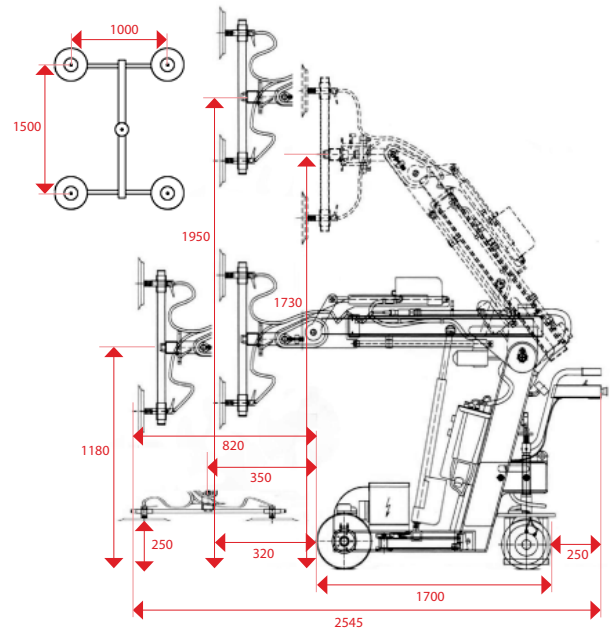

[www.instant.no](http://www.instant.no)